

SimpleCircuitBoards.com

Interval Timer Relay Board



Here is a board that, when power is applied, will cycle on and off a relay. The relay on time and off time can be independently controlled with “timing resistors” which are easily replaceable by the User. See below for a table of resistor values and associated time delays. Time delays can range from less than a second to about 25 minutes. The relay will continue cycling on and off until the power to the board is turned off.

This board is based on the 556 Timer and the relay is rated for up to 10 amps. The relay has Normally Open (NO) and Normally Closed (NC) terminal connections.

An LED indicates when the NO contacts of the relay are closed.

The board requires 12VDC for operation. Other voltages are available upon request.

Miscellaneous Information:

-

Specifications:

- Input Power: 12 VDC
- Output: NO and NC Contacts
- Relay Rating: 10A Max
- Board Dimensions: 1.75 x 3.5 inches

Example Hook-Up

Below is an example of how this board might be hooked up:

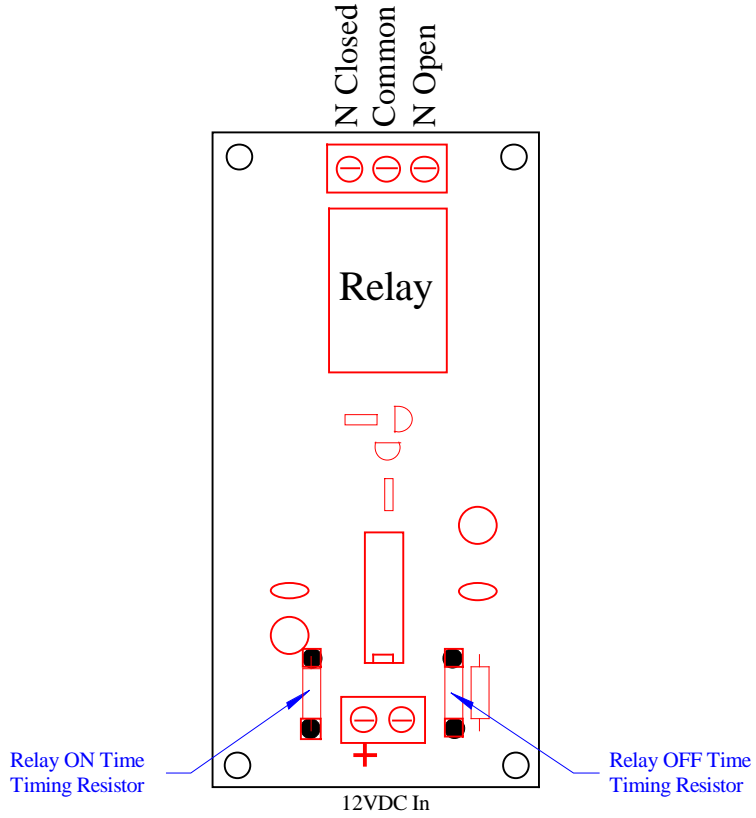

Resistor Values / Time Delay* Chart

Resistor Value (K)	Delay			Resistor Value (K)	Delay		
	Seconds	+5%	-5%		Minutes	+5%	-5%
10 K	1.4	1.3	1.5	220 K	0.52	0.49	0.54
11 K	1.6	1.5	1.6	240 K	0.56	0.54	0.59
12 K	1.7	1.6	1.8	270 K	0.63	0.60	0.67
13 K	1.8	1.7	1.9	300 K	0.71	0.67	0.74
15 K	2.1	2.0	2.2	330 K	0.78	0.74	0.81
16 K	2.3	2.1	2.4	360 K	0.85	0.80	0.89
18 K	2.5	2.4	2.7	390 K	0.92	0.87	0.96
20 K	2.8	2.7	3.0	430 K	1.01	0.96	1.06
22 K	3.1	2.9	3.3	470 K	1.11	1.05	1.16
24 K	3.4	3.2	3.6	510 K	1.20	1.14	1.26
27 K	3.8	3.6	4.0	560 K	1.32	1.25	1.38
30 K	4.2	4.0	4.4	620 K	1.46	1.39	1.53
33 K	4.7	4.4	4.9	680 K	1.60	1.52	1.68
36 K	5.1	4.8	5.3	750 K	1.76	1.68	1.85
39 K	5.5	5.2	5.8	820 K	1.93	1.83	2.02
43 K	6.1	5.8	6.4	910 K	2.14	2.03	2.25
47 K	6.6	6.3	7.0	1.0 M	2.35	2.23	2.47
51 K	7.2	6.8	7.6	1.1 M	2.59	2.46	2.72
56 K	7.9	7.5	8.3	1.2 M	2.82	2.68	2.96
62 K	8.7	8.3	9.2	1.3 M	3.06	2.90	3.21
68 K	9.6	9.1	10.1	1.5 M	3.53	3.35	3.70
75 K	10.6	10.1	11.1	1.6 M	3.76	3.57	3.95
82 K	11.6	11.0	12.1	1.8 M	4.23	4.02	4.44
91 K	12.8	12.2	13.5	2.0 M	4.70	4.47	4.94
100 K	14.1	13.4	14.8	2.2 M	5.17	4.91	5.43
110 K	15.5	14.7	16.3	2.4 M	5.64	5.36	5.93
120 K	16.9	16.1	17.8	2.7 M	6.35	6.03	6.67
130 K	18.3	17.4	19.3	3.0 M	7.06	6.70	7.41
150 K	21.2	20.1	22.2	3.3 M	7.76	7.37	8.15
160 K	22.6	21.4	23.7	3.6 M	8.47	8.04	8.89
180 K	25.4	24.1	26.7	3.9 M	9.17	8.71	9.63
200 K	28.2	26.8	29.6	4.7 M	11.05	10.50	11.61
				5.1 M	11.99	11.39	12.59
				5.6 M	13.17	12.51	13.83
				6.2 M	14.58	13.85	15.31
				6.8 M	15.99	15.19	16.79
				7.5 M	17.64	16.76	18.52
				8.2 M	19.28	18.32	20.25
				9.1 M	21.40	20.33	22.47
				10.0 M	23.52	22.34	24.69

* Above time values are calculated and are approximate. You may have to experiment a little to get the exact time you want. Use ¼ watt resistors – available at any electronics supply store (i.e., Radio Shack). The +/- 5% Values above show approximate range expected when using 5% resistors.

Disclaimer:

These boards are designed for educational use only. In no circumstances should these circuit boards be used in critical situations where failure could mean injury or property damage.

For more information, contact me at:

Info@SimpleCircuitBoards.com